

NO	DESCRIPTION	SIZE	Q'TY	REMARKS
1	2083 REGULATOR	2"	1	A. M. C
2	1843 REGULATOR	2"	1	A. M. C
3	FILTER (G1.5, HOAC, 1MPa)	2"	1	SE JONG
4	D.P GAUGE (0-70kPa)	1/4"	1	SE JONG
5	RECORDER (1-0.1MPa, 7D)	2PEN	1	SE JONG
6	J48KH RELIEF	1"	1	JEAVONS
7	PRESSURE GAUGE (0-1.5MPa)	∅100	1	WOO JIN
8	PRESSURE GAUGE (0-0.1MPa)	∅100	1	WOO JIN
9	PRESSURE GAUGE (0-10kPa)	∅100	1	WOO JIN
10	BALL VALVE (1MPa)	2"	4	TAI YANG

HOUSING

1. MAT'L : SUS304, 1.0t
2. SIZE : 1800Lx700Wx1350H
3. DOOR : 전면 (1개소)
4. 환기구 : 250x200 (4개소)

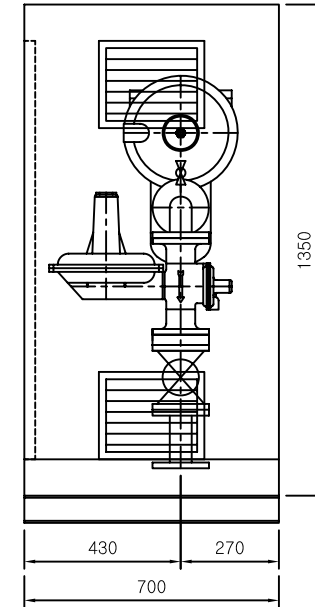
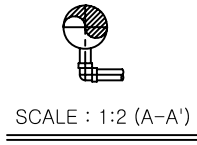
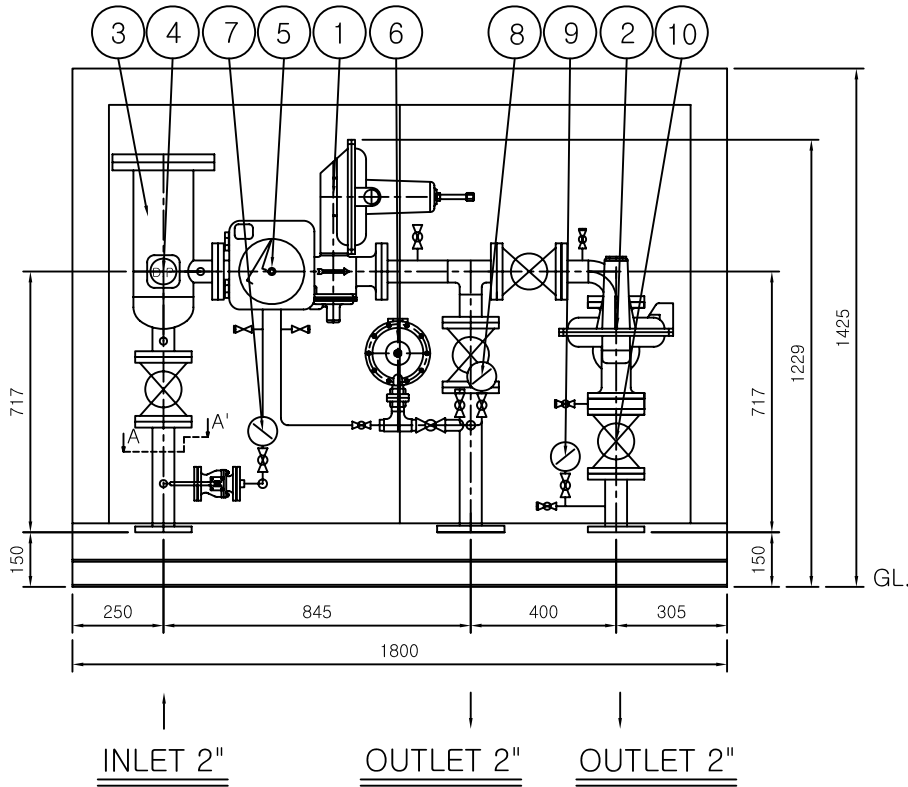

DWG:	PROJECT TITLE	DATE	SCALE	P/SCALE	DWG NO.
K.S.K		2004. 02. 18.	1/10	A-2	DH1404047
DES: N.G.K	REVISION				
CHK: Y.K.P	DWG				
APPD: J.G.R	DES				
	CHK	TITLE 2083 (S)+1843 (S) REG' STATION			
		世宗에이엠씨株式會社 SEJONG-AMC CORPORATION			